

**BRAND INDIA ENGINEERING
E-CATALOGUE**

Date: 19-01-2025

Kirloskar Brothers Limited

**Yamuna, Survey No. 98/(3-7), Baner, Pune-
411 045, India
PUNE
PIN - 411 045**

**Mr. Anurag Kumar
PHONE - +91 20 2721
4444
EMAIL -
response@kbl.co.in
WEB -
www.kirloskarpumps.com**

Kirloskar Brothers Limited (KBL) is a world class pump manufacturing company with expertise in engineering and manufacture of systems for fluid management. Established in 1888 and incorporated in 1920, KBL is the flagship company of the \$ 2.1 billion Kirloskar Group. KBL, a market leader, provides complete fluid management solutions for large infrastructure projects in the areas of water supply, power plants, irrigation, oil & gas and marine & defence. We engineer and manufacture industrial, agriculture and domestic pumps, valves and hydro turbines. KBL has eight manufacturing facilities in India at Kirloskarvadi, Dewas, Kondhapuri, Shirwal, Sanand, Kaniyur, Kolhapur and Karad. In addition, KBL has global manufacturing and packaging facilities in Egypt, South Africa, Thailand, The Netherlands, United Arab Emirates, United Kingdom and United States of America. KBL has 12,700 channel partners in India and 80 overseas and is supported by best-in-class network of Authorised Centres and Authorised Refurbishment Centres across the country. All plants of KBL are ISO 9001 & ISO 14001, OHSAS 18001, ISO 14000 Environment Standard certified. They apply Total Quality Management tools using European Foundation for Quality Management (EFQM) model.

[Products Description](#)

BRAND INDIA ENGINEERING E-CATALOGUE

KPD

Technical Details

These pumps are developed for process applications and are generally conforming to API 610. These are gland packed or mechanically sealed. These pumps are ideal for air conditioning, condensate extraction, distilleries, edible oil, sugar and textile. Delivery size ranges from 20 mm to 200 mm. • Delivery size up to 200 mm • Capacity up to 2200 m³ /hr • Head up to 150 m • Temperature up to (-) 50 °C to 350 °C

ITC HS Code

841370

Certification Category

System Standard

Certification/ Standard

ISO

Issuing Agency

Bureau Veritas

Date of Issue

16-12-2015

Date of Expiry

Certificate Image



End Use Sectors

• Edible Oil, Sugar, Textile and Process Industries, Water Treatment Plants and Distilleries

Product Images

0

Romak

Technical Details

Romak (RMK) pump is a Magnetic Drive Pump comprising Permanent magnets. It is a sealless pump and is used for handling various types of clear/ clean chemical liquids without any suspended particles in process industries. Delivery size : Up to 100mm Capacity : Up to 300 m³/hr Head : Up to 150 m working pressure : 16 bar Temperature : (-) 50 °C to 180 °C

ITC HS Code

841311

Certification Category

System Standard

BRAND INDIA ENGINEERING E-CATALOGUE

Certification/ Standard

ISO

Issuing Agency

Date of Issue

Date of Expiry

Certificate Image



End Use Sectors

• Chemicals, Pharmaceuticals, • Petrochemicals

Product Images

0

GK(P)

Technical Details

These pumps are developed for process applications and are generally conforming to ISO 2858 / DIN EN 22858 / ISO 5199. These pumps are ideal for Acids / Alkalies, Hydrocarbons, oils, Various Process Chemicals, Food processing units. Delivery size up to 150 mm. Delivery size : Up to 150 mm Capacity : up to 500 m³/h Head : up to 150 m working pressure : 16-25 bar Temperature : Up to 180°C

ITC HS Code

841311

Certification Category

System Standard

Certification/ Standard

ISO

BRAND INDIA ENGINEERING E-CATALOGUE

Issuing Agency
Date of Issue
Date of Expiry
Certificate Image



End Use Sectors
Product Images

Process chemicals, oil and gas, food processing units, etc
0

I-CP

Technical Details

• Seal less and glandless pump • End suction pump comprises of permanent magnet • Delivery size : Up to 100mm • Capacity : Up to 300 m³/hr • Head : Up to 150 m • working pressure : 16 bar • Temperature : (-) 50 °C to 180 °C

ITC HS Code

841311

Certification Category

System Standard

Certification/ Standard

ISO

Issuing Agency

Bureau Veritas

Date of Issue

16-12-2015

Date of Expiry

14-09-2018

BRAND INDIA ENGINEERING E-CATALOGUE

Certificate Image



End Use Sectors

• Chemicals - • Pharmaceuticals • Petrochemicals

Product Images

0

I-CM Canned Motor pumps

Technical Details

Canned Motor pumps are ideal for pumping corrosive and noxious fluids that are used in chemical and process industry, refrigeration plants, paint industry and refinery & petrochemicals. • Delivery size : 32 to 50 mm • Capacity : 4 to 80 m³/hr • Head : Up to 60 m • working pressure : 16 bar • Temperature : Up to 90°C

ITC HS Code

841311

Certification Category

System Standard

Certification/ Standard

ISO

Issuing Agency

Bureau Veritas

Date of Issue

16-12-2015

Date of Expiry

14-09-2018

BRAND INDIA ENGINEERING E-CATALOGUE

Certificate Image



End Use Sectors

Chemicals, process industry, refrigeration plants, paint industry and refinery & petrochemicals

Product Images

0

AT

Technical Details

AT pump is used in handling Thermic fluids across various applications in process industries. The pump can handle fluid upto 350°C. The design is as per standard - EN 22858. • Delivery size : 32 to 80 mm • Capacity : up to 250 m³/hr • Head : up to 100 meters • working pressure : 16-25 bar • Temperature : +180°C to +350°C

ITC HS Code

841311

Certification Category

System Standard

Certification/ Standard

ISO

Issuing Agency

Bureau Veritas

Date of Issue

16-12-2015

Date of Expiry

14-09-2018

Certificate Image

BRAND INDIA ENGINEERING E-CATALOGUE

End Use Sectors
Product Images

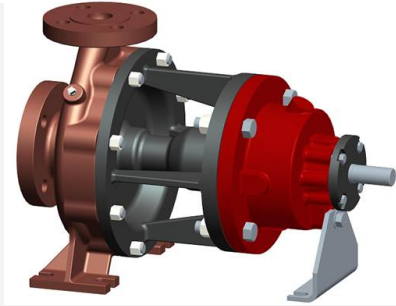

Hydro-Pneumatic System

Technical Details

Types of Systems: Constant Speed System – FX : Tank Filling Water Transfer, Residential housing, Small size commercial – Residential buildings Cascade system – MX (Only 1 VFD common to all pumps) : Medium size commercial – Residential buildings, Demand based industrial applications All Pump VFD system – EX (all pumps having their individual VFD) : Townships, Hospitals, Airports, Malls, Metros, Demand based industrial applications

ITC HS Code

841319

Certification Category

System Standard

Certification/ Standard

ISO

Issuing Agency

Bureau Veritas

Date of Issue

16-12-2015

Date of Expiry

Certificate Image



End Use Sectors

B&C

Product Images

0

BRAND INDIA ENGINEERING E-CATALOGUE

Technical Details

Fire pumps for high-rise buildings. Flow Range: 700 m³/hr (3082 US gpm) Head Range: Up to 500 m (1640 ft) No. of outlets: up to 5 nos. Type of Execution: Both Horizontal and vertical Std MOC (Casing/Impeller/Shaft): CI/Bronze/SS Available in both gland pack/mechanical seal 50Hz /60 Hz availability

ITC HS Code

841319

Certification Category

System Standard

Certification/ Standard

ISO

Issuing Agency

Date of Issue

Date of Expiry

Certificate Image



End Use Sectors

B&C

Product Images

0

BRAND INDIA ENGINEERING E-CATALOGUE

Technical Details

These pumps are called Concrete Volute Pumps (CVP) because the casing and suction draft tube is cast in-situ concrete with rotating metallic part. These pumps comprise concrete volute casing, draft tube, grouted embedded, components and rotating assembly. These pumps find applications where large quantity of flow is required to be handled, most suitable for sea water application.

ITC HS Code

841340

Certification Category

System Standard

Certification/ Standard

ISO

Issuing Agency

Bureau Veritas

Date of Issue

16-12-2015

Date of Expiry

Certificate Image



End Use Sectors

Water, Industry, B&C, Irrigation, etc. • Thermal and Nuclear power plants • Flood control • Storm water • Dry Docks

Product Images

0

UP / UPL / UPH / UP (T) Axially Split Case Pumps

Technical Details

These pumps are gland packed and have mechanical seal. These are mainly used in water supply, irrigation, power plants and can have delivery size up to 1100 mm.
• Delivery size up to 1100 mm • Capacity up to 20,000 m³ /hr • Head up to 160 m • Temperature (-) 10 °C to 90 °C

ITC HS Code

841319

Certification Category

System Standard

Certification/ Standard

ISO

Issuing Agency

Bureau Veritas

Date of Issue

16-12-2015

BRAND INDIA ENGINEERING E-CATALOGUE

Date of Expiry
Certificate Image



End Use Sectors

• Power plants • Paper, Sugar, Textile mills • Fire fighting Water Supply Irrigation • Air-conditioning

Product Images

0

Vertical Turbine Pumps

Technical Details

These pumps are constructed rigidly to ensure vibration free operation. Hydraulic design is being updated with our continuous R&D efforts to meet requirements of higher efficiency and lower submergence, taking care of other parameters such as, high reliability and optimum system design. • Delivery size up to 2200 mm • Capacity up to 40,000 m³/hr • Head up to 200 m

ITC HS Code

841319

Certification Category

System Standard

Certification/ Standard

ISO

Issuing Agency

Bureau Veritas

Date of Issue

16-12-2015

Date of Expiry

Certificate Image



BRAND INDIA ENGINEERING E-CATALOGUE

End Use Sectors	• Steel, Cement industries • Refineries Thermal and Nuclear power plants, Sea water on off-shore platforms, Condensate extraction, Fire fighting Pumps • Flood control, Dry Docks
Product Images	0

Axially Split Case Pumps

Technical Details	These are horizontally axially split casing, single stage, double suction or single suction pumps with horizontal shaft and detachable stuffing box called insert with horizontal axially split volute type. The impeller is accurately balanced by double or single suction. These pumps are used in handling water with slight impurities, petroleum refineries, conditioning and refrigeration system and so on. • Delivery size up to 350 mm • Capacity up to 4500 m ³ /hr • Head up to 330 m • Temperature (-) 10 °C to 100 °C
ITC HS Code	841319
Certification Category	System Standard
Certification/ Standard	ISO
Issuing Agency	Bureau Veritas
Date of Issue	16-12-2015
Date of Expiry	
Certificate Image	

End Use Sectors	• Petroleum refineries, conditioning and refrigeration system, Petroleum refineries • Fire protection systems and mining • Air-conditioning and refrigeration systems • Water/Liquids with slight impurities
Product Images	0

Auto Prime

BRAND INDIA ENGINEERING E-CATALOGUE

Technical Details

The Autoprime range is a proven, versatile and comprehensive product range suitable for use in a variety of applications worldwide. The Autoprime is primarily sold to rental organisations, contractors, utility companies, open cast mines and municipalities providing a durable solution to all your needs.

ITC HS Code

841319

Certification Category

System Standard

Certification/ Standard

ISO

Issuing Agency

Bureau Veritas

Date of Issue

Date of Expiry

Certificate Image



End Use Sectors

• Water (Dewatering), Flood Control.

Product Images

0

Sluice Valve

Technical Details

These valves are available in non rising as well as in rising spindle type suitable for clear water up to 450 C. These valves are designed with total compliance with applicable design and testing standards. All designs are validated for stress analysis. Sluice valves find wide application in water works, water/effluent/sewage treatment plants. • Manufacturing Standard - BS 5163 / IS14846 • Size Range 32 to 1500mm • Pressure Ratings PN10, PN16 • End Connection Flanged

ITC HS Code

848110

Certification Category

System Standard

Certification/ Standard

ISO

BRAND INDIA ENGINEERING E-CATALOGUE

Issuing Agency
Date of Issue
Date of Expiry
Certificate Image

Bureau Veritas

16-12-2015



End Use Sectors
Product Images

• Water works • Water / Effluent / Sewage treatment plants • Fire Fighting • Power

0

Multi-door non-return valve

Technical Details

These valves are very useful in preventing back flow of water to the pump. These valves have minimum head loss and can be very competitive in terms of long service life. These valves are very useful in waterworks pipelines to reduce hammer effect. Non slam and quick closing characteristics have made this product a very demandable one across markets. • Manufacturing Standard BS 5153 (EN 12334) / IS 5312 Part 1 & 2 • Size Range 40 to 1500 mm • Pressure Ratings PN6, PN10, PN16 • End Connection Flanged

ITC HS Code

848130

Certification Category

System Standard

Certification/ Standard

ISO

Issuing Agency

Bureau Veritas

Date of Issue

16-12-2015

Date of Expiry

14-09-2018

BRAND INDIA ENGINEERING E-CATALOGUE

Certificate Image



End Use Sectors

B&C, Water

Product Images

0

Suction Diffuser Valve

Technical Details

- Installed at the inlet of the pump.
- Serves as a filter to remove suspended debris.
- Act as a flow straightener and guides pumping media at the inlet of impeller.
- Stabilizes flow at inlet of the pump.
- Cast Iron body for ANSI class 125 and ductile iron for ANSI class 250.
- Flanges as per ANSI standard / Customer requirement.
- Acts as an elbow Suction Diffuser
- Size Range: 2" to 20"
- Pressure Rating: ANSI Class 125 and class 250
- ANSI Standard Flanges

ITC HS Code

848110

Certification Category

System Standard

Certification/ Standard

ISO

Issuing Agency

Bureau Veritas

Date of Issue

16-12-2015

Date of Expiry

14-09-2018

BRAND INDIA ENGINEERING E-CATALOGUE

Certificate Image



End Use Sectors

• HVAC Building and construction, Industry (Pharmaceuticals/ Bottling plants/ Chemical/ Food and Beverages)

Product Images

0

Triple Duty Valve

Technical Details

Triple Duty Valve General Description • Installed at the discharge side of pump systems. • Spring-loaded disc prevents valve chatter. • Balancing valve/ Priming with by-pass function. • Inline or 90° flow arrangement is possible. • Cast Iron body for ANSI class 125 and ductile iron for ANSI class 250. • Flanges as per ANSI standard / Customer requirement. • Throttling operation. • Size Range: 2" to 24" • Pressure Rating: ANSI Class 125 and class 250 • ANSI Standard Flanges

ITC HS Code

848110

Certification Category

System Standard

Certification/ Standard

ISO

Issuing Agency

Bureau Veritas

Date of Issue

16-12-2015

Date of Expiry

14-09-2018

BRAND INDIA ENGINEERING E-CATALOGUE

Certificate Image

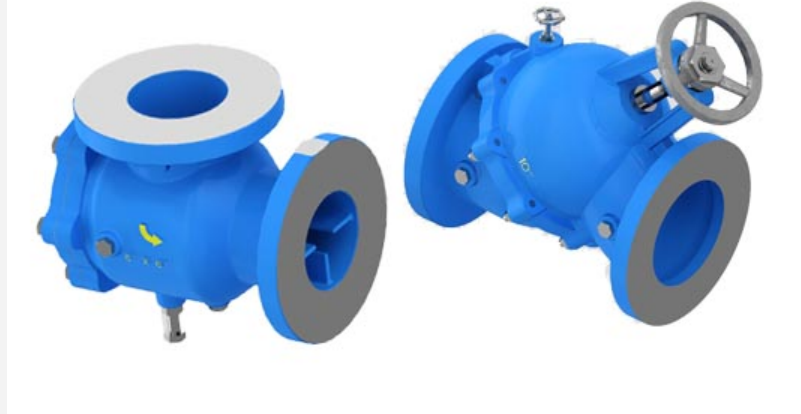

End Use Sectors

• HVAC Building and construction, Industry (Pharmaceuticals/ Bottling plants/ Chemical/ Food and Beverages)

Product Images

0

V-FLOW

Technical Details

Uniquely designed pump with extra heavy duty construction for trouble free performance and durability.

ITC HS Code

841370

Certification Category

System Standard

Certification/ Standard

ISO

Issuing Agency

Bureau Veritas

Date of Issue

16-12-2015

Date of Expiry

14-09-2018

BRAND INDIA ENGINEERING E-CATALOGUE

Certificate Image



End Use Sectors

Domestic

Product Images

0

KS4

Technical Details

A multi-utility pump which features a stainless steel motor body that can be easily rewound. Technical Specifications • Head : 5 to 50 meters • Capacity : 2560 to 140 LPH • Power Rating : 0.37 Kw/ 0.5 HP to 0.75 Kw/ 1.0 HP • Voltage Range : 180 to 240 Volts(1 phase

ITC HS Code

841370

Certification Category

System Standard

Certification/ Standard

ISO

Issuing Agency

Bureau Veritas

Date of Issue

16-12-2015

Date of Expiry

14-09-2018

BRAND INDIA ENGINEERING E-CATALOGUE

Certificate Image



End Use Sectors

Domestic, Industrial

Product Images

0

Pumpa Puzha

Technical Details

These pumps are designed for better performance in domestic applications. They have high quality aluminum extruded motor body with chrome plated shaft. These pump can withstand wide voltage fluctuations from 180 V to 240 V. They are ideal for water supply for domestic use in Bungalows, Apartments, Hotels, Hospitals, Farm houses, etc. Useful in home pressure booster systems, lawn sprinklers, overhead tanks and watering for gardens. Extra high head of 50 meters makes this pump ideal for domestic as well as institutional use. • Head : 6 to 50 meters • Capacity : 2580 to 140 LPH • Power rating : 0.37 kW to 0.75 kW • Voltage range : 180 - 240 volts

ITC HS Code

841370

Certification Category

System Standard

Certification/ Standard

ISO

BRAND INDIA ENGINEERING E-CATALOGUE

Issuing Agency
Date of Issue
Date of Expiry
Certificate Image



End Use Sectors Domestic, Small Industries
Product Images 0

KDS+ Pump

Technical Details These pumps can withstand voltage fluctuations from 180-240 volts. These have dynamically balanced rotating parts to ensure minimum vibrations. Cast iron impeller, delivery casing, these pumps are suitable for gardening and small farm irrigation, agri for clear water handling, water supply for agri, used in apartments, buildings and hotels. • Head range Upto 76 m • Discharge range Upto 72 lps • Power rating 0.37 – 22 kW (0.5 – 30 HP) • Voltage range 300 – 440 V (3 phase)

ITC HS Code 841370

Certification Category System Standard

BRAND INDIA ENGINEERING E-CATALOGUE

Certification/ Standard

ISO

Issuing Agency

Bureau Veritas

Date of Issue

16-12-2015

Date of Expiry

Certificate Image



End Use Sectors

• Air-conditioning • Refrigeration • Cooling towers • Industries for clear water handling at higher pressures • Fire fighting

Product Images

0

Sectors of Interest

Industry, Water, Irrigation, Building & Construction, Agriculture, Oil & Gas and Valves

Is OEM Supplier?

Indigenous

Is After Sales Service Provider?

Yes

Importance of niche products

Potential market of niche products

Product Supply Record

Patented Technologies

Awards/Accolades